



Circadian rhythm-related antibodies

What is a circadian rhythm?

Living organisms on the earth synchronize their activity to a 24-hour light and dark cycle generated by the rotation of the earth. This biological rhythm is called the circadian rhythm, which means “approximately one day.” Each cell within unicellular organisms, cultured cell lines, and cells composing tissues has its own circadian clock.

In animals, the circadian rhythm of cells in tissues is synchronized by the suprachiasmatic nucleus (SCN) located in the hypothalamus via nerves or humoral signals.

The SCN clock is called the central clock and that within each tissue is called the peripheral clock.

Recently, the molecular mechanism for the oscillation of the circadian rhythm has been elucidated and the approximately-24-hour rhythm was found to be generated by a transcription–translation feedback-loop of clock genes expressed by almost all cells. In particular, BMAL1, CLOCK, PERs, and CRYs play central roles in the oscillation of the circadian rhythm and rhythmically regulate the expression of downstream genes (hereinafter referred to as clock-controlled genes [CCGs]).

Approximately 10% of all genes expressed in the liver and heart are considered CCGs. Stable oscillation of the expression of clock genes regulates numerous life activities, including the approximately-24-hour sleep/awake cycle, blood pressure, body temperature, and hormone secretion. Disruption of the circadian rhythm and polymorphisms in circadian rhythm-related genes are reportedly associated with various diseases, such as hypertension, diabetes, and sleep disturbance. Clock genes have been thoroughly investigated, not only as direct targets for drug discovery, but also from the standpoint of drug metabolizing efficiency. MBL offers a wide choice of antibodies against circadian rhythm-related genes that can be used with WB and ChIP. Please take this opportunity to try these products.

Circadian rhythm and diseases

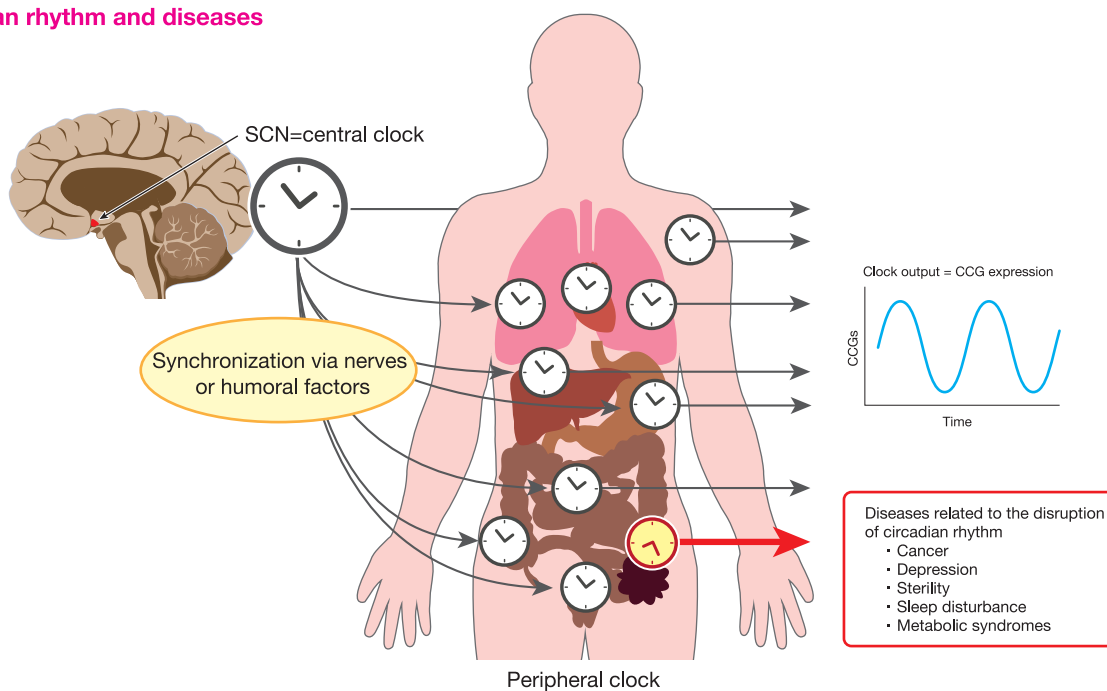

Code.	Product name	Clone	Isotype	Package	Application	Cross reactivity
D335-3	Anti-BMAL1 (Mouse) mAb	B1BH2	Mouse IgG1 κ	100 μg/100 μL	WB	Mo
D333-3	Anti-CLOCK (Mouse) mAb	CLSP3	Mouse IgG1 κ	100 μg/100 μL	WB / IP*	Mo
D334-3	Anti-CLOCK (Mouse) mAb	CLNT1	Mouse IgG1 κ	100 μg/100 μL	WB / IP*	Mo
D349-3	Anti-CLOCK (Mouse) mAb	CLSP4	Mouse IgG1 κ	100 μg/100 μL	WB / IP / ChIP*	Mo
PM075	Anti-GNAT2 (Zebrafish) pAb	Polyclonal	Rabbit Ig (aff.)	100 μL	WB / IF	Zebrafish
PM079	Anti-DBP (Mouse) pAb	Polyclonal	Rabbit Ig (aff.)	100μL	WB	Mo

Application: WB: Western Blotting IP: Immunoprecipitation ChIP: Chromatin Immunoprecipitation

*: Reported in the literature (unconfirmed by MBL).

Cross-reactive species: Mo: Mouse

Anti-CLOCK (Mouse) mAb

Anti-BMAL1 (Mouse) mAb

Core Feed Back Loop

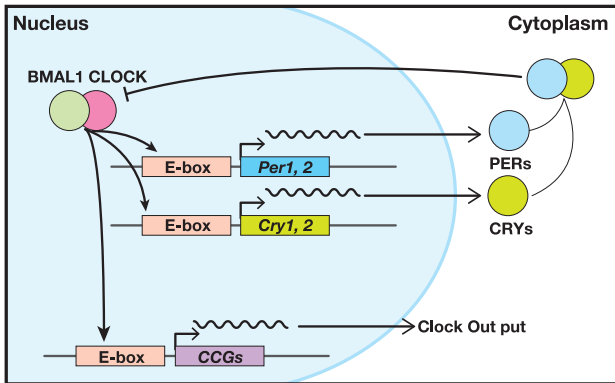

BMAL1 and CLOCK form a heterodimer, which binds to the regulatory region (E-box) in *Per1/2* and *Cry1/2* to positively regulate transcription. PER and CRY proteins then form a complex, migrate to the nucleus, and negatively regulate the function of the BMAL1/CLOCK complex. CCGs with E-box elements are expressed and are regulated by the BMAL1/CLOCK complex, and various genes are expressed according to circadian rhythm.

ChIP-Seq analysis of mouse CLOCK from liver nuclear extracts*

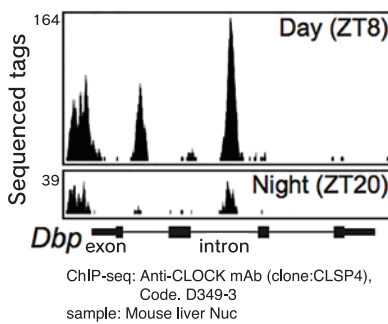

Western blot analysis of mouse CLOCK from liver nuclear extracts*

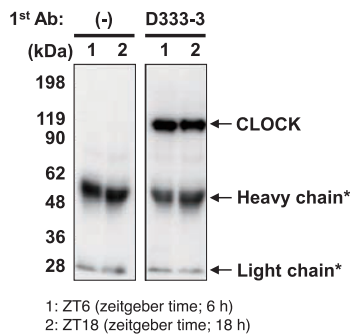

Western blot analysis of mouse BMAL1 from liver nuclear extracts*

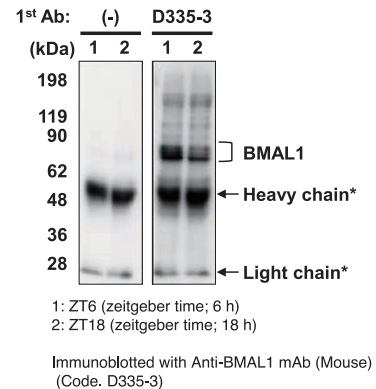

*The heavy / light chains derived from IgG in the samples. (These bands are detected depending on a sample.)

Anti-DBP (Mouse) pAb

Dbp and E4bp4

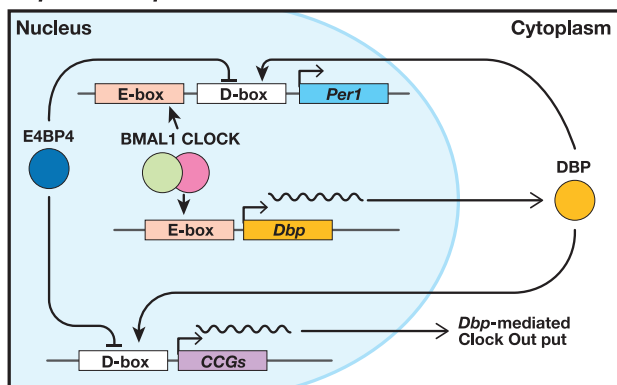

Dbp is regulated by the BMAL1/CLOCK complex and is expressed rhythmically. DBP binds to D-box to positively regulate the expression of CCGs, while E4BP4 negatively regulates expression. DBP and E4BP4 are known to be expressed in opposite phases. DBP and E4BP4 are known to also bind to D-box in the promoter region of *Per1*, a clock factor expressed upstream, to regulate the expression of *Per1*.

Rhythmic expression of mouse DBP analyzed by Western blot in liver nuclear extracts*

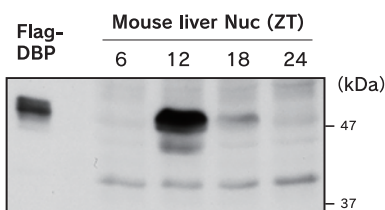

WB: Anti-DBP pAb, Code. PM079

*Data is provided courtesy of Prof. Yoshitaka Fukada, Assoc. Prof. Hikari Yoshitane, Kentaro Hirose, and Rina Fukawa, Department of Biophysics and Biochemistry, Graduate School of Science, The University of Tokyo.